



## MRO Activities in HAL for meeting defence and civil requirements

---

# Evolution of HAL

85 years of experience in Aerospace & Defence

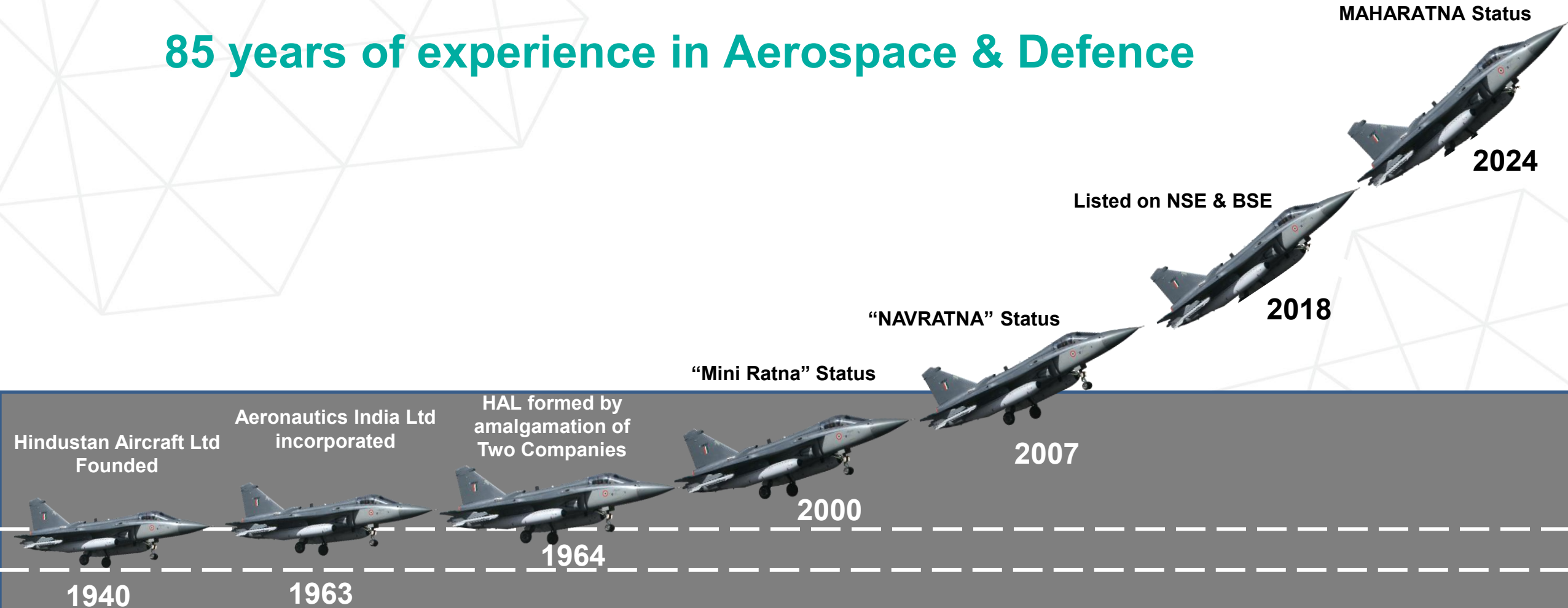

# HAL TODAY

## Our Vision

To be a global leader in the Aerospace & Defence Industry

## Our Mission

We are committed to deliver superior technology solutions to the customers by leveraging our infrastructure and Design, Manufacture & Service skills, for achieving business excellence

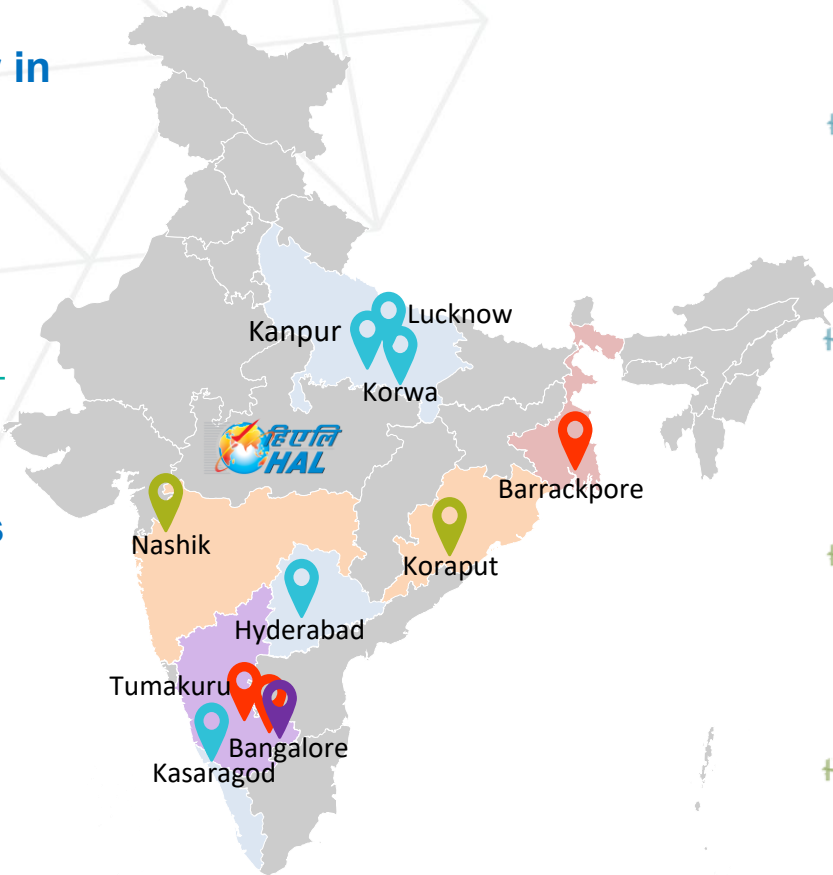

Achieved “Maharatna” status on 12<sup>th</sup> Oct’24



Ranked 1<sup>st</sup> among Defence PSU  
As per Market Capitalization in India



21<sup>st</sup> Among Global Aerospace Companies  
By Sales



21 Divisions and 9 R&D Centres  
Presence in 7 states, 10 geographical locations



23,000+ Workforce



Estimated revenue generated Rs. 32,250Cr  
in FY 2025-26

# CAPABILITIES

## MRO

Maintenance, Repair & Overhaul of Aircraft, Helicopter, Engines & Accessories.



## Mid Life Upgrade

Aircraft Mid life Upgradation



## Manufacturing

Manufacture of Aircraft, Helicopter, Engines & Systems



## Aerospace Program

Manufacturing of Structure, Boosters for launch vehicles and Cryogenic engine



## Design & Development

Design & Development of Fixed & Rotary Wing Platforms, Aero-Engines, UAVs & Systems



## Missile Integration

Missile integration on existing platforms

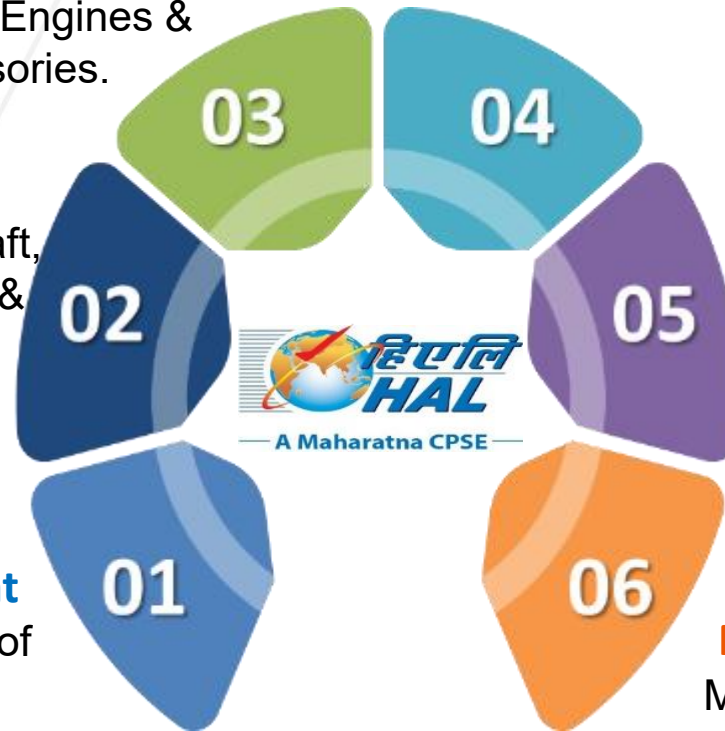

# Capabilities-Manufacturing

## Manufacture of Fighters, Trainers, Helicopters, Transport Aircraft, Engines, Avionic Systems and its accessories

- Aircraft produced - 17 types indigenous & 14 types under license
- Engines produced – 5 types Russian, 8 types Western & 2 Indigenous origin

## Major On going Projects

### LCA MK1A:

- Supply of 83 Nos. (73 Fighter + 10 Trainer) to IAF
- Production Capacity:
  - Bangalore: 2 Production lines (16 aircraft per annum),  
Nasik: 1 Production line (8 aircraft per annum capacity) by 2026-27
  - Augmentation to 30 aircraft per annum by 2027-28

### Advanced Light Helicopter (ALH):

- Supply of 25 Nos. to Indian Army (IA) & 9 Nos. to Indian Coast Guard (ICG)
- Production Capacity: 30 helicopters per annum

### AL31FP Engines for Su-30 MKI aircraft:

- Supply of 240 Nos. to IAF
- Production Capacity: 30 engines per annum



# Capabilities- MRO & Mid Life Upgrade (MLU)

## Maintenance, Repair & Overhaul of Aircraft, Helicopter, Engines & Accessories.

- **12548** Aircraft Overhauled (35 types - Fixed Wing, Rotary Wing & Transport aircraft)
- **37033** Engines Overhauled (21 types -Russian, Western & Indigenous origin)

## Major MRO & MLU Projects

### Mirage 2000:

- 4<sup>th</sup> generation Multi Role fighter
- MRO & MLU Capacity : 7 per annum



### Su 30 MKI :

- 4.5<sup>th</sup> generation Multi Role fighter
- MRO Capacity: 20 aircraft per annum



### Hawk:

- Advanced Jet Trainer
- MRO Capacity: 12 aircraft per annum



### Advanced Light Helicopter (ALH):

- 5.5. ton Utility Helicopter
- MRO Capacity: 41 helicopters per annum



# Capabilities- Research & Development

Design & Development of Fixed & Rotary Wing Platforms, Engines, UAVs & Systems

## Major Ongoing D&D Projects

### LCA MK2

- Multirole, All-weather 4.5 Generation Combat Aircraft
- Partnership with ADA for design and manufacturing
- Ideal platform to replace Mirage 2000, Jaguar & MiG-29

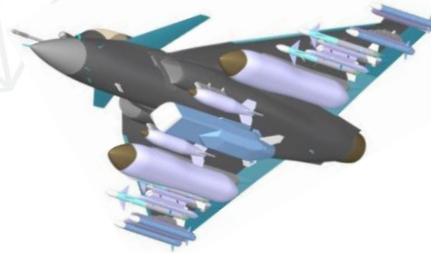

### TEDBF

- Twin engine, deck based fighter aircraft for Indian Navy
- Replacement for MiG-29K aircraft
- ADA is the lead agency with HAL as design partner



### AMCA

- 5+ generation Stealth, Medium Weight category, Multi Role, Twin Engine, Fighter Aircraft with a swing role capability.
- ADA is the lead agency with HAL as design partner



### Combat Air Teaming System (CATS)

- Manned Unmanned Teaming System (MUM-T)
- Teaming with manned aircraft, intelligent swarming, autonomous operations

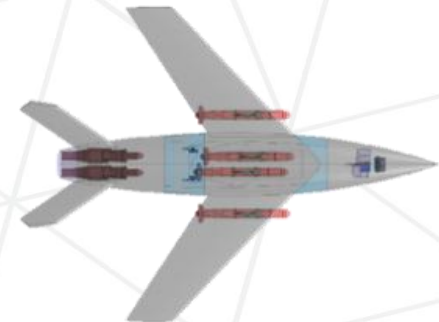

# Capabilities- Research & Development

Design & Development of Fixed & Rotary Wing Platforms, Engines, UAVs & Systems

## Major Ongoing D&D Projects

### Indian Multirole Helicopter (IMRH) / Deck Based Multi Role Helicopter (DBMRH)

- Medium Lift helicopter of 13 to 14 Ton weight class
- Ideal platform to replace Mi-8/Mi-17 from 2028 onwards.



### Su 30MKI Upgrade

- Indigenous upgrade by integration of advanced avionic systems, Sensors with better performance characteristics to enhance combat capability



### Aravalli Engine for IMRH/DBMRH

- JV incorporated for Design, Development, Manufacture and Supply of the engines



# Capabilities- Systems & Solutions



Mission Computer



Digital Map Generator



Full Mission Simulator



Smart Multifunctional Display



Automatic Target Recognition System



Software Defined Radio



Automatic Flight Control System (AFCS)



Integrated Avionics & Display System (IADS)



Main Rotor Actuator



Infra Red Search & Track



ASTRA (BVR Missile) Integration



Gas Turbine Electric Generator (GTEG-60)

# Capabilities- Allied Operations

## Space programs of ISRO

- Aerostructure
- Cryogenic engines
- Propellant Tank



Aero Structure

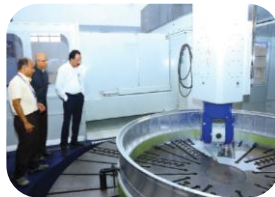

Launch Vehicle  
Mark3 Facility



Cryogenic Engine  
Facility

## Industrial and Marine Gas Turbine

- Manufacture & MRO of LM-2500 marine gas turbine engines for aircraft carriers, frigates & corvettes
- MRO of Industrial Avon and Allison engines.



LM-2500

# Exports



**30 Countries**

**(Aircraft / Helicopters / Spares / ROH)  
Additionally exports by JVs**

**3 Countries**

**Overseas Offices (LO & Mktg Office)**

# FUTURE PRODUCTS

- Light Combat Aircraft MkII



- AMCA-Advance Medium Combat Aircraft



- TEDBF-Twin Engine Deck Based Fighter



- IMRH – Indian Multi Role Helicopter



- CATS – Combat Air Teaming System

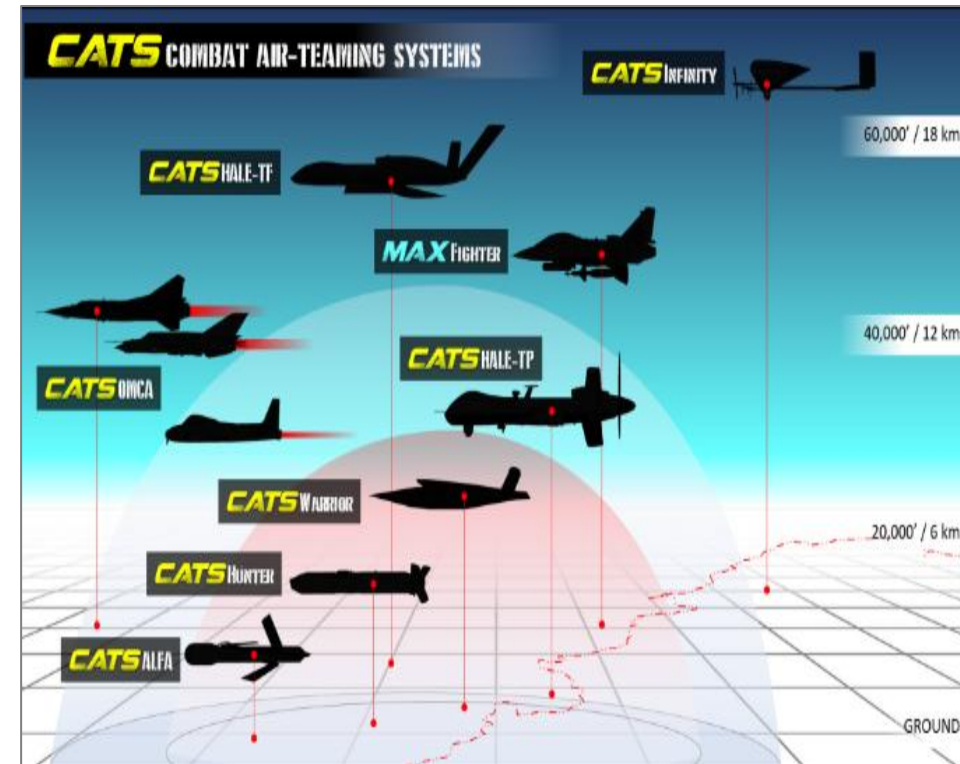

# CURRENT OPERATIONS – MANUFACTURING, REPAIR & OVERHAUL

*Capability to Manufacture, Repair, Overhaul, Upgrade & Maintain a vast portfolio of products*



# We Provide 360° Support to our Customers

## Technical Investigation

- Aircraft incident and accident at customer bases.

## Documentation for Aircraft maintenance

- Release of Aircraft Maintenance Documents

## Training to customer

- Aircraft operation and maintenance.
- Crew training for Indigenous platform

## Service Instructions

- Release of STI.
- Airmen notifications

## Special Technical Instructions

- Release of Service Instruction

## Warranty and Spares Support

- After sales support
- Warranty Management

## Aircraft Modifications

- Incorporation of new payloads
- Upgrades

## Engineering support to operating fleet

- Snag Dispositions
- On-Site Repair / rectifications
- Design Liaison Activities
- Defect Investigations

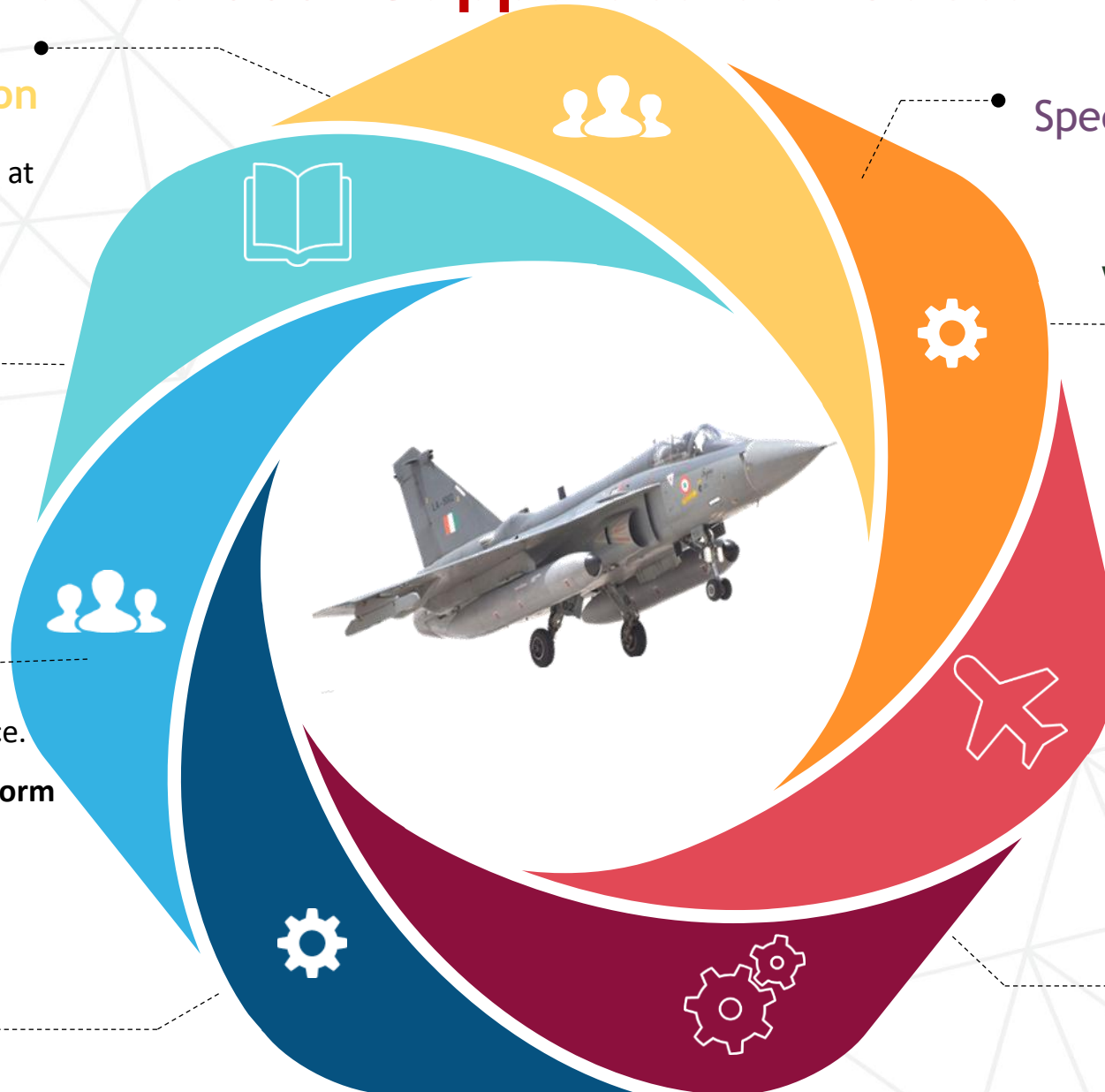

# Hindustan Aeronautics Limited

## Civil MRO Vision & Roadmap



# Vision of HAL



“To make India a Global Hub and self-reliant in Aviation MRO thereby bolstering the Make-In-India Mission of the Country”

**“Having alignment with Convergence Mission of GOI to cross utilize the resources of Defence and Civil Aviation”**

# HAL's Approach towards Convergence

Identify existing  
HAL facilities/  
Capabilities



**Identify**



**Collaborate**

Collaborate with suitable  
Partners/OEMs for  
utilization of identified  
facilities into new domain

Upgrade/Modify existing  
facilities for new  
requirements with OEMs/  
Collaborative partners.



**Upgrade**



**Exploit**

Create multiple Business  
Model for utilization of these  
facilities towards new verticals  
for effective exploitation

# Vision of HAL

## AIRPORT OPERATIONS

Freight Conversion,  
Refurbishment



Airport & Allied



Component MRO

COMPONENT MRO

Base Maintenance  
Painting & Structure  
Repairs

AIRFRAME MRO

Special  
Services



ENGINE MRO



Landing Gear MRO

**“Developing Integrated  
Civil MRO Hub”**

# ATC and Airport Infrastructure



# Airport and ATC Facilities

- DGCA licenced for all weather operations.
- ATC & Metrological Dept. (HAL)
- ATC Watch-Hours: 24x7
- Equipped to Handle Night Operations; RWY, TWY lighting on 2-Circuits.
- Exclusive Cargo Apron at Distance of 200 M from Cargo Complex
- Terminal for Immigration and Customs.

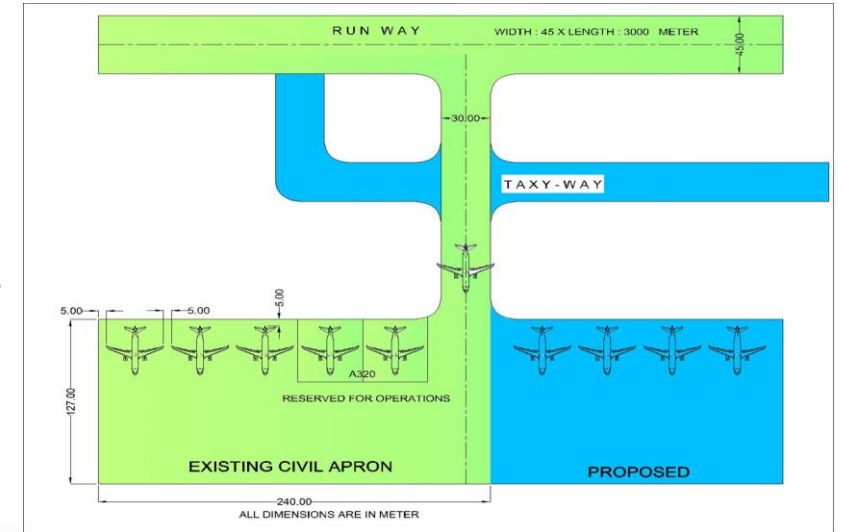

# Interconnected MRO and Painting Hangar



# Facilities: Airframe MRO

## Clear Dimension:

- Hangar-1: 102m\*58.60m\*13m
- Hangar-2: 102m\*48.6\*13m
- Hangar-3: 68m\*58.6m\*13m



## Features:

- Equipped with all GHE/GSE, tools and power supply
- Ample office space storage and kitting
- Connected to runway and painting hangar

# MRO Hangar: Facilities



**Stores and Office Infrastructure**

# DGCA Approved Painting Hangar



- Closed Door Hangar
- Can accommodate one narrow-body aircraft

- Equipped with state of the art exhaust system





**Capabilities:  
Component MRO**

# Overview: Capabilities for Component MRO

01

## Hydraulic & Fuel

Actuators, valves Range upto 380 kg/cm<sup>2</sup>

02

## Pneumatic

Range 0.2 to 400 Kg/cm<sup>2</sup>

03

## Instrument & Navigation

Stand by, Pitot, INGPS, MFDs

04

## Electrical

Thermal, Engine Starter, Circuit breakers, fuse boxes, APT etc

05

## Controls

Fly by Wire

06

## Radio & Radar

Communication, Radar systems



Mechanical Aggregates 150 Types



Electrical, Instrument & Nav Aggregates 291 Types



Radio & Radar Aggregates 125 types



# Component MRO Plan

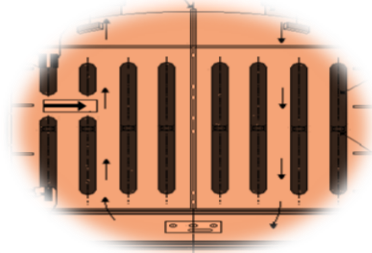

Landing Gears, Actuators, Hydraulic Actuators

**Phase I**



Hydraulic, Pneumatic and Fuel Controls

**Phase II**



Aircond., IC & Rain Protection, Electrical

**Phase III**



Commn, Navigation, Flight Controls & IRS

**Phase IV**



Engines and APUs

**Phase V**



# Centre for Excellence for Landing Gears

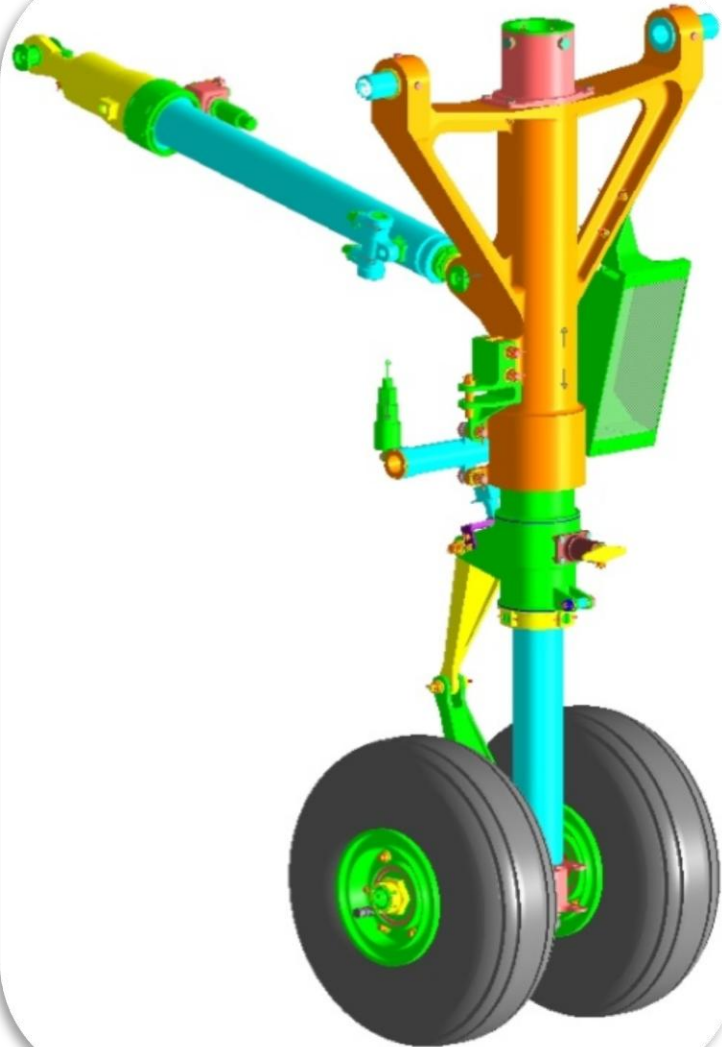

## Fixed Wing

Mfg-MiG-21, MiG-27, LCA, LCA Navy  
ROH- Su-30MKI, Mirage-2000,  
MiG-21, MiG-27, LCA



## Trainer

IJT



## Rotary Wing



# Experience: Manufacturing & ROH of Landing Gear



**1000+ Repair  
&  
Overhaul**

**500+  
Manufacturing**

Since 1964

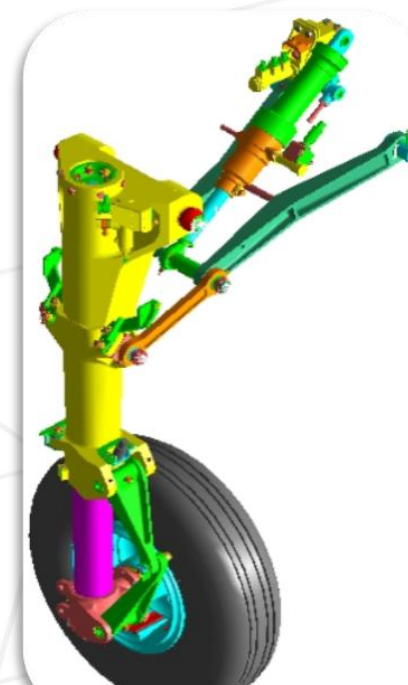
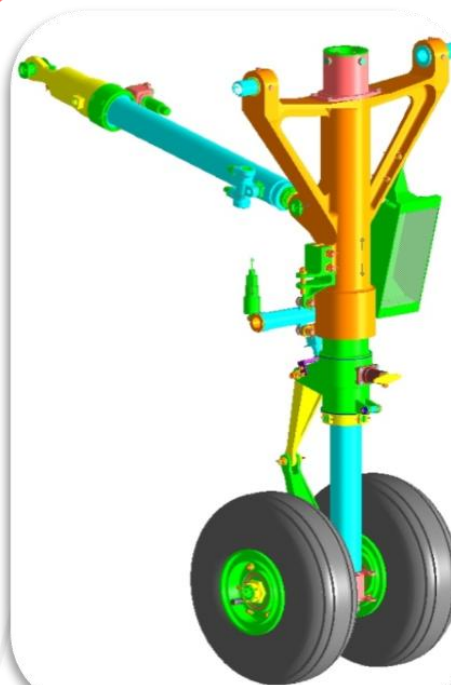

# Landing Gear Complex

## Capabilities:

- ✓ OEM of Landing Gears for all Indigenous Programs like LCA, ALH, LCH, ALH CIVIL
- ✓ MRO Western Origin Platforms (Mirage-2000)
- ✓ **CAR21 and CAR145 approved**



## Indigenous Programs



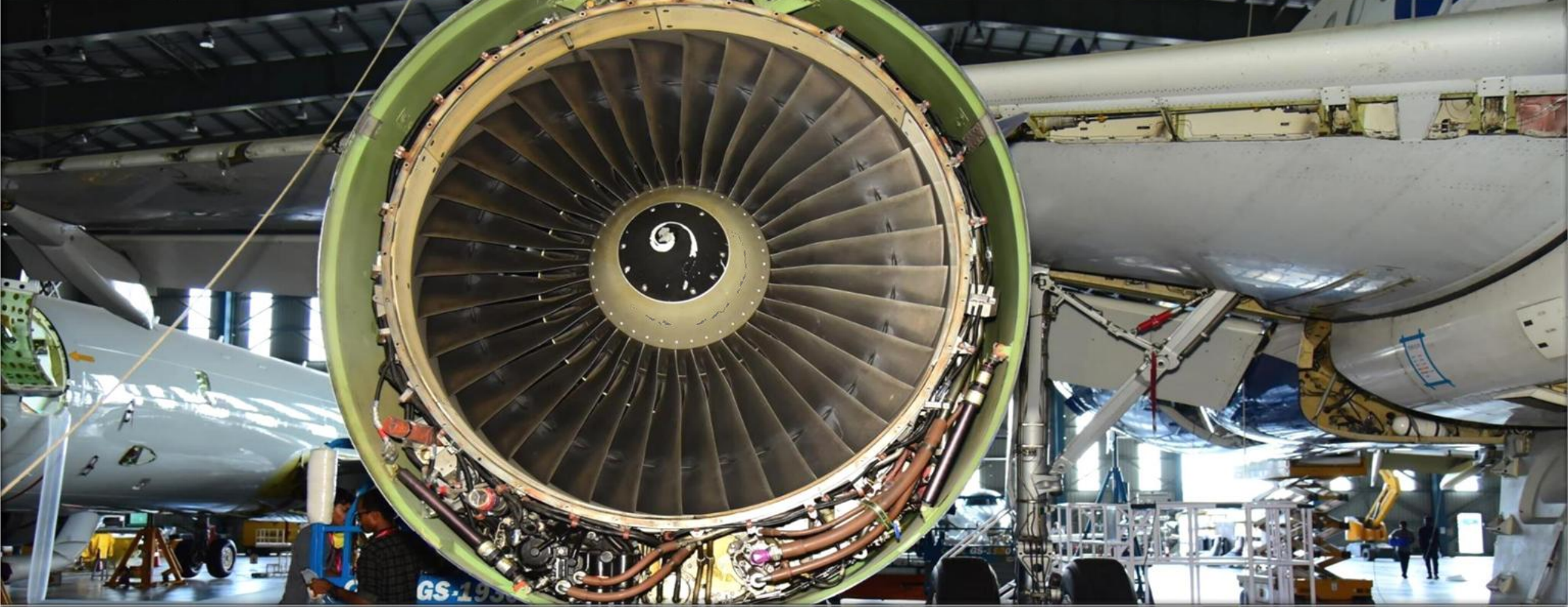







## Skill Development

- 30 person attempting AME exam, 12 B1(Mechanical) and 18 B2(Avionics) Started clearing examination
- 7 Technician cleared all modules of AME and obtained BAMEC certificate. 3 Technicians obtained RTR-A license.
- One BAMEC holder completed Level 3 Type Training.
- 5 personnel cleared more than 5 modules out of 10 modules

# Challenges:

-  **Certification Differences:** Defence-trained personnel and facilities require separate, time consuming and expensive approvals for civil work, limiting the direct transferability of skills and infrastructure.
-  **Different regulating authority:** Defence MRO operates under CEMILAC and DGAQA, while civil aviation is regulated by the DGCA, making it difficult to merge workforce, certification, and quality protocols.
-  **Skilled manpower:** Though defence technicians are highly skilled, still they lack familiarity with civil aviation standard and regulatory compliances.
-  **Procurement procedure:** Existing procurement procedure does not match the pace of requirements of civil MRO.
-  **Tools:** Civil MRO requires meticulous documentation of all tools used, including certificates of conformity.
-  **Data safety:** Separate storage for Defence and Civil MRO data.



जय हिन्द  
Jai Hind